



FEATURES

- Automatic recharging spring pump
- Strong PP body
- Umbrella valves
- Stainless steel spring not in contact with chemical
- Changeable coloured ABS cups
- Installatio kit included
- No electric power needed
- Totally tool free wall mounting and maintenance
- Adjustable dosage: 7/15/22/30 cc per push by using the ring spacer included
- Tip for lock-out time
- Stainless steel spout
- Operating Temperature: 5-50°C
- Storage Temperature: -20÷60°C

FIELD APPLICATION:

- All purpose, to fill bottles, buckets and sinks with a lot of sanitizers or institutional cleaning products

PACKAGING INCLUDES:

- Tip for lock-out time
- Screws and anchors
- Mounting bracket
- Hose 8mm ID – 12mm OD
- Additional fitting for the spout exit
- 2pcs rings spacers

AVAILABLE OPTIONS

- Coloured Cups
- Stainless steel tank rack (5 or 10 liters)
- Ceramic bottom filter

DIMENSIONS

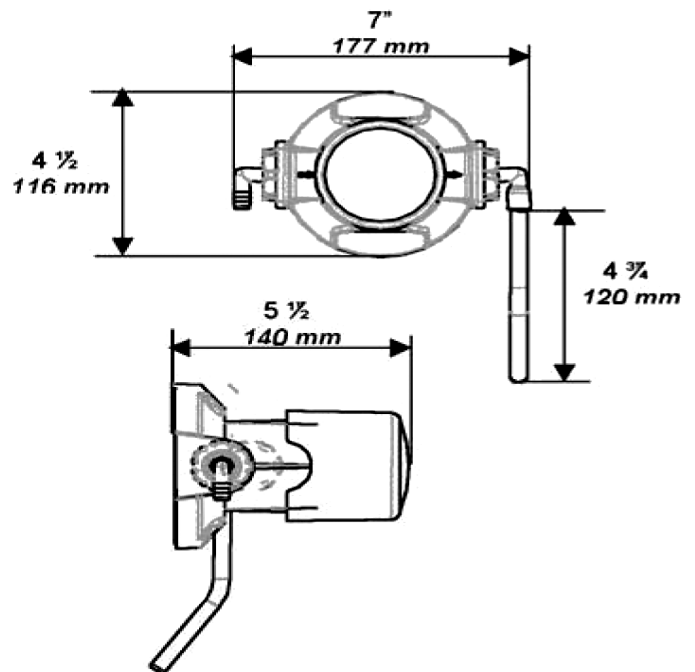

MODELS AND CODES

Gasket type	pH range	Code
FPM	0÷5	HP30F0000000
Silicone	5÷10	HP30S0000000
EPDM	10÷14	HP30E0000000