

**SPECIFICATIONS:**

**MODEL NUMBER:** 2088-562-144  
**PUMP DESIGN:** Positive Displacement 3 Chamber Diaphragm Pump  
**CHECK VALVE:** (1-Way Operation) Prevents Reverse Flow  
**CAM:** 2.5 Degree  
**MOTOR:** Permanent Magnet, P/N 11-160-00, Thermally Protected  
**VOLTAGE:** 230 VAC Nominal  
**PRESSURE SWITCH:** Adjustable from 30-50 PSI. Factory Set @ 45 PSI Shut-Off,  
 Turn On 25 ±5 PSI  
**LIQUID TEMPERATURE:** 130 Degrees Fahrenheit (54 Degrees Centigrade) Max.  
**PRIME:** Self-Priming Up To 8.5 Ft. Vertical,  
 Max. Inlet Pressure 30 PSI (2.1 Bar)  
**PORTS:** 1/2" - 14 Male Parallel Thread  
**MATERIAL OF CONSTRUCTION:**  
**PLASTICS-** Polypropylene  
**VALVES-** Santoprene  
**DIAPHRAGM-** Santoprene  
**FASTENERS-** Zinc Plated Steel  
**NET WEIGHT:** 4.0 Lbs (1.8 Kg)  
**DUTY CYCLE:** Intermittent (See Temp. Rise Chart)  
**TYPICAL APPLICATIONS:** Water Delivery  
**APPROVALS:** N.S.F. Listed

**DIMENSIONS:**

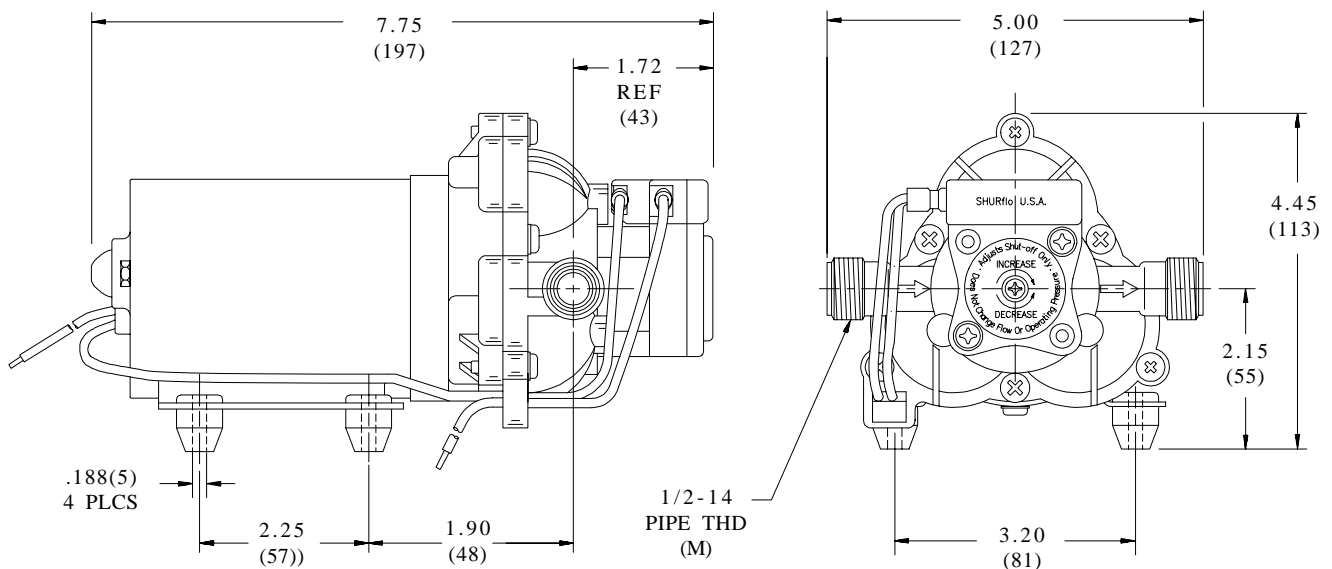

### TEMPERATURE RISE

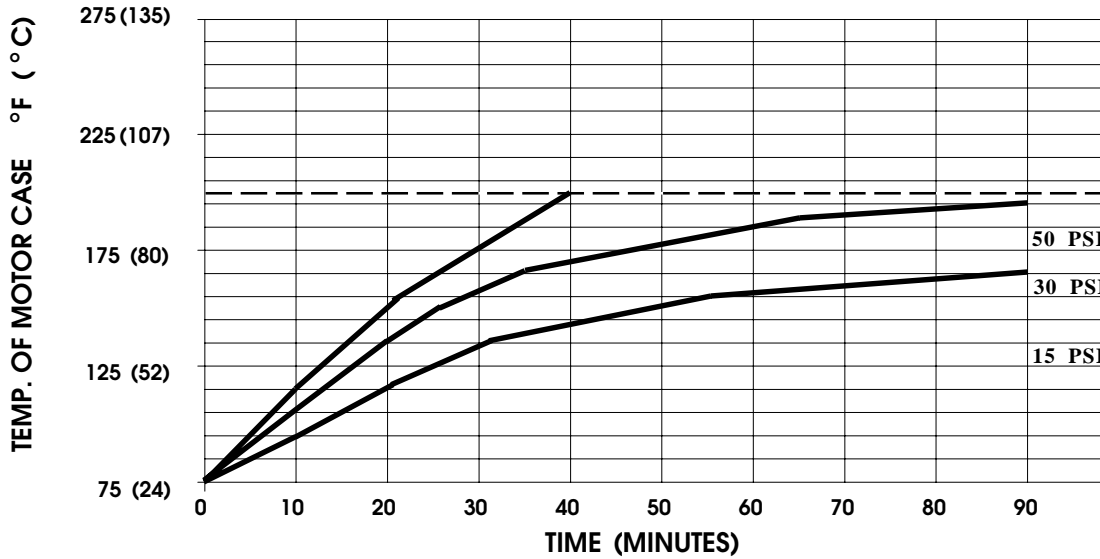

THIS GRAPH IS FOR USE AS A DESIGN GUIDE. IT IS BASED ON RUNNING CONTINUOUSLY WITH AN AMBIENT TEMPERATURE OF 75° F IN STILL AIR. THE THERMAL BREAKER WILL OPEN WHEN THE CASE TEMPERATURE REACHES 200° F.

(----- TRIP POINT OF THERMAL PROTECTOR)

### TYPICAL PERFORMANCE

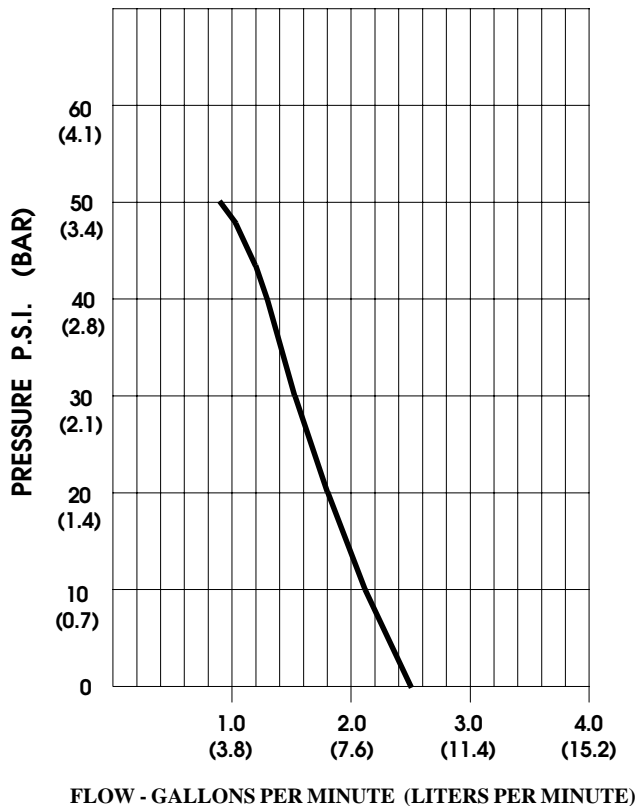

PRESSURE (PSI)	FLOW (GPM/LIT)	RPM MIN/MAX	CURRENT (AMPS)	VOLTAGE (VOLTS)
OPEN	2.50/9.5	1955/2065	0.22	230 VAC
10	2.11/8.0	1845/1940	0.24	"
20	1.80/6.8	1635/1735	0.30	"
30	1.50/5.7	1400/1550	0.33	"
40	1.25/4.7	1270/1430	0.37	"
50	0.95/3.6	1080/1340	0.42	"

-SPECIFICATIONS SUBJECT TO CHANGE WITHOUT NOTICE.

-ALL DATA BASED ON TESTING WITH WATER.