

TYPICAL APPLICATIONS

This pump may be used for general water transfer.
Do not use for flammable liquids.

PUMP

Type	3 Chamber Diaphragm
Ports	1/2" NPT Male
Flow	2.7 GPM [10.2 LPM] Max
Liquid	130 °F [54 °C] Max
Prime	9 feet [2.7 M]
Inlet PSI	30 PSI [2.1 Bar] Max
Run Dry	Yes

ELECTRICAL

Motor	230 VAC 50/60Hz Thermally Protected
Power	0.9 Amps Max
Fuse	Recommended Slow Blow Fuse 1.0 Amps
Control	Pressure Switch 45 PSI [3.1 Bar]

MATERIALS

Housing	Polypropylene
Valves	EPDM
Diaphragm	Santoprene

WARRANTY

2 Year Limited Warranty

Shipping

Net Weight 4 Lb [1.8 Kg] each

Shurflo pump



PRESSURE		FLOW		CURRENT
BAR	PSI	GPM	LPM	AMPS
0.0	0	2.7	10.2	0.32
1.4	20	1.8	6.8	0.34
2.8	40	1.3	4.8	0.57
3.4	50	0.9	3.6	0.61

Typical Dimensions

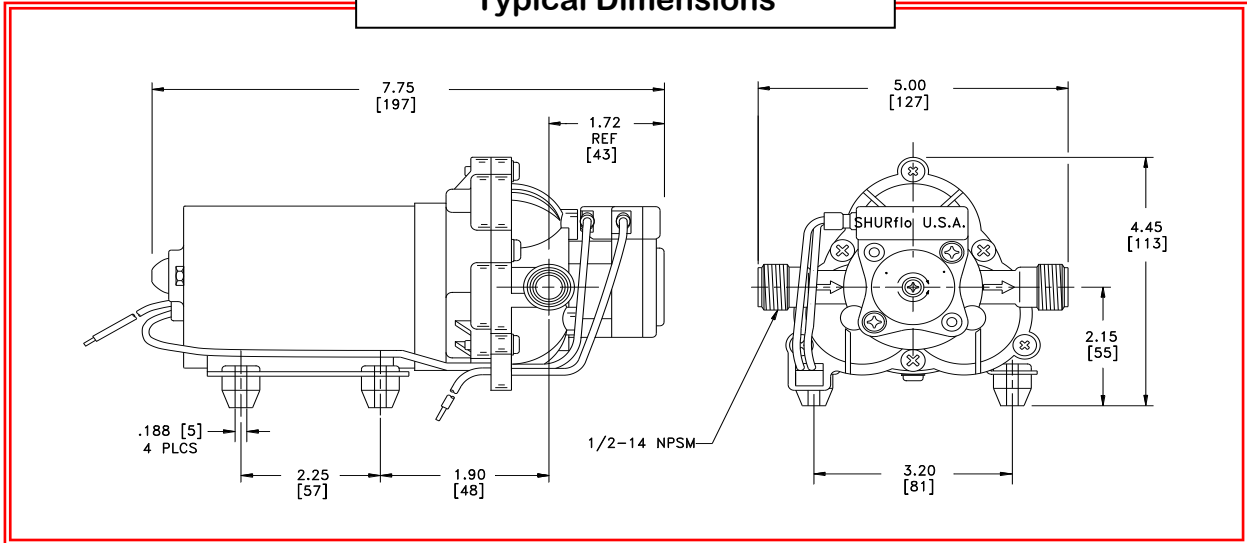

* ISO Registered Facility

SHURflo

First in Fluid Innovation

SHURflo reserves the right to update specifications, prices, or make substitutions.

IMPEA
E-cerpadla